

E-140

Supercritical CO₂ Extractor



DESCRIPTION

The extraktLAB E-140 is the fastest, most advanced and most powerful CO₂ extraction machine on the market today. The machine is designed to provide high yield in a short period of time while satisfying the traceability requirements for GMP compliancy.

extraktLAB's supercritical CO₂ extraction equipment can run a variety of extraction methods.

FEATURES

-  **Sub or Supercritical CO₂ Extractions**
-  **Full Spectrum Extracts**
-  **Fully Automated Methods**
-  **UL, ASME, PED, EPR Certified**
-  **Scalable**
-  **GMP Compliant Software**



EXTENDED

PROCESSING POWER

- Up to 422 lbs/day
- 8 kg/cycle biomass
- 60 min/cycle @ 10% plant potency
- 90+% hemp efficiency
- 95+% marijuana efficiency
- 24 sq ft footprint
- 67 Full Load Amps (FLA)

PROCESS CONTROL

- Programmable methods
- Automated extraction cycles
- Independent vessel control
- 0 - 5000 psi
- 25 - 100° C
- Cyclonic separation
- Data capture/reporting

GMP COMPLIANCE

- Automated process control
- Batch, operator, parameter tracking
- FDA approved materials
- Instrument calibrations
- Clean in place
- International certifications
- Calibration/maintenance tracking

SPECIFICATIONS

ATTRIBUTE	VALUE	ATTRIBUTE	VALUE
Biomass Input / Cycle	5-8kg	Full Load Amps	67
Cycle Time @ 10% pp	60 min	Voltage	208-240 VAC
Biomass Processing / Day	192 kg / 422 lbs	Phase	3
Efficiency – Oil Recovery	Hemp 90+% / Marijuana 95+%	Frequency	50-60 Hz
Extraction Vessels	2 × 20L	Flow Control	Manual or Automatic
Collection Vessels	3 × 2.5L	CO2 Supply	750-850 psi inlet
CO2 Recycle Vessel	20L	Wetted Materials	FDA approved, ASME 304 and 316 Structural Grade Steel
Footprint	24 sq ft	Separation Principle	Cyclonic& Solubility
Shipping Weight	4,300 lbs	Datasystem	Export data, diagnostics and event logging, data traceability, unlimited working level access, user traceability method, CO2 lot, input lot trace
Dimensions (w/o light mast)	H 72" × L 99" × W 34"	Regulatory Compliance	21 CFR Part 117,211, 177 and Health Canada equivalents, P.E. stamped according to ASME DIV II VII-2 PED compliant, CE marked, notified body Lloyd's Register, CRN number
Operating Pressure	0 to 5000 psi	Cleaning Methods	Supercritical CO2, alcohol, non-polar solvents
Operating Temperature	25 to 100°C	Calibration / Maintenance	Software tracking built-in
Sound Pressure	50 db	Training records	Software tracking built-in
User Interface	Touch Screen HMI Panel		

LINE DRAWINGS

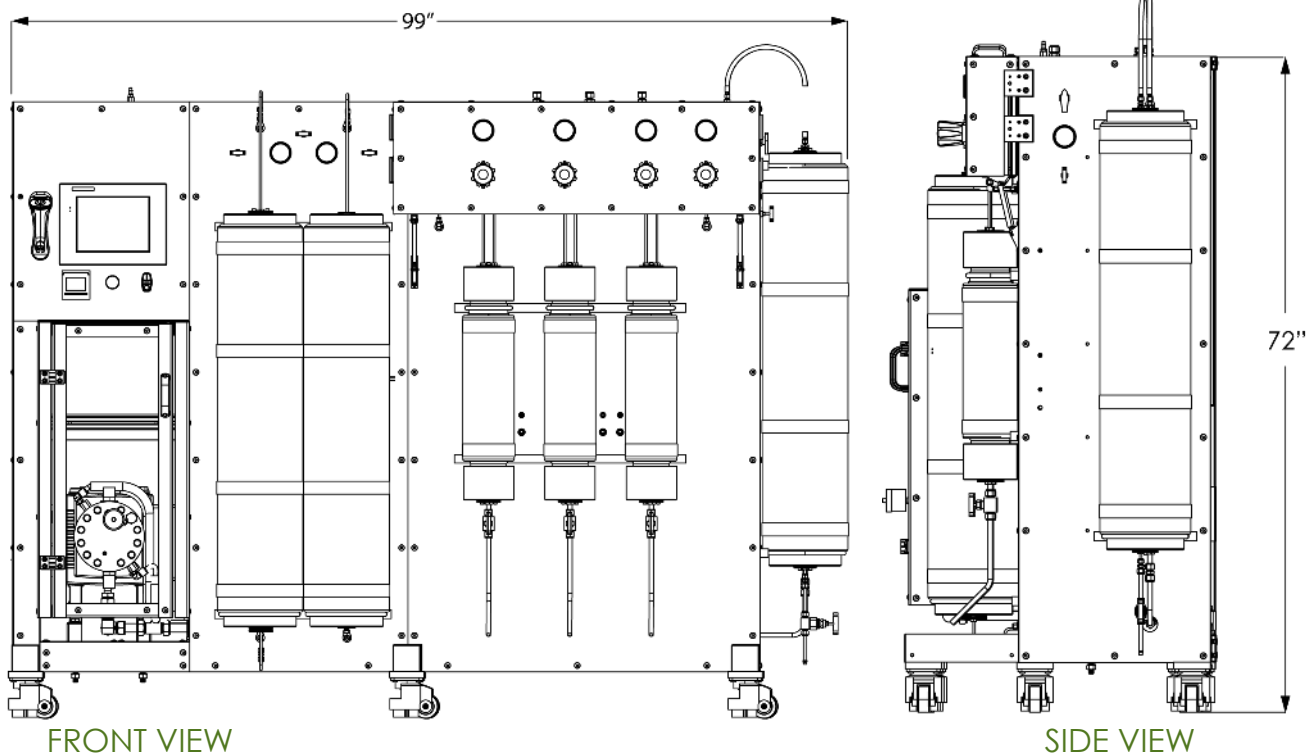

E-140